

Instruction Manual for Model AR2500 Turbo Scanning Monitor



AOR Ltd

2-6-4 Misuji, Taito-ku, Tokyo 111-0055, Japan.

Tel: +81 3 3865 1695 Fax: +81 3 3865 1697

post@ajorja.com www.ajorja.com

AOR (UK) Ltd - AOR Manufacturing Ltd

4E East Mill, Bridgefoot, Belper, Derbys DE56 2UA, England

Tel: +44 1773 880788 Fax: +44 1773 880780

info@ajor.co.uk www.demon.co.uk/ajor

AOR USA, INC.

20665 S. Western Avenue, Suite # 112

Torrance, CA. 90501, USA

Tel: (310) 787 8615 Fax: (310) 787 8619

info@ajorusa.com www.ajorusa.com

This manual is protected by copyright AOR Ltd 1991. No information contained in this manual may be copied or transferred by any means without the prior written consent of AOR Ltd.

Every effort has been made to make this manual correct and up to date. Due to continuous development of the receiver and by error or omissions anomalies may be found and this is acknowledged.

Most apparent faults are due to accidental miss-operation of the receiver, carefully read all of the manual before deciding to return the set for repair.

**AOR Ltd.,
2-6-4 Misuji,
Taito-Ku,
Tokyo 111.
Japan.
Tel: 03-3865-1681
Fax: 03-3865-1697**

General

This AOR wide band scanning receiver is renowned for it's high standards of performance and range of facilities. Although offering a long list of facilities and operating modes, the receiver remains reasonably easy to operate. The display often provides 'prompts' for selected operations.

All information such as frequency, mode, bank etcetera is presented in an easy to see Liquid Crystal Display (LCD). The display is provided with a lamp for night time use to increase visibility.

The receiver has an exceptionally wide frequency coverage from 5 MHz to 550 MHz then from 800 MHz to 1300 MHz (1.3 GHz!!!). The modes available are AM, FM (narrow), FM (wide) and SSB (USB, LSB, CW) when using the Beat Frequency Oscillator (BFO). All available modes may be selected at any frequency within the receiver's coverage.

Although carefully designed, this receiver (like all receivers) suffers from a degree of internal noises known as spuri. They are a product of the receiver's circuitry and do not represent a fault.

The aerial connection is of the standard BNC type allowing straight forward connection to almost any aerial. There is also a 20dB attenuator selectable from the rear panel to increase versatility especially when listening to shortwave.

There is a massive 'Elephant memory'. Storage is by EEPROM (no batteries required). There are 1984 memories held as 62 banks of 32 and 16 additional search banks which store mode, frequency limits and increment. The scan speed is 'turbo charged' scanning upto 36 channels or increments per second.

The internal microprocessor sorts frequencies into numerical order within a bank and scans them in strict order. This ensures the fastest possible speed with the highest probability of signal locking.

The receiver may be plugged directly into any Personal Computer via the RS232 9 pin serial socket. Optional software is available for the IBM-PC range of computers (or you can write you own, further information is given at the end of this manual).

A thin plastic film is sometimes present on the front panel and display. This is to provide added protection to the surfaces below during manufacture. This film may be removed to enhance appearance and improve visibility.

Accessories supplied

AC power supply

12V DC lead for mobile operation

Mobile mount

Telescopic aerial

Operating manual

Power requirements

The receiver is powered from a nominal 13.8V DC power supply, the polarity is **centre positive**. The supplied AC power supply is not regulated as this is provided by the receiver. Although the provided power supply allows operation in all modes, better SSB audio quality may be achieved when a separate regulated power supply is used. The current capacity of a regulated external power supply should be 1 Amp or greater. If placed into mobile operation, your vehicle should be negative ground.

Controls

The receiver is housed in an attractive, strong plastic cabinet. Controls for operation are located on the front face of the cabinet.

Front panel:

1. POWER switch. Located on the lower left-hand side of the front panel. The receiver is switched ON when this switch is depressed and OFF when pressed a second time.

2. VOL (volume) and MS (main shift) controls. The volume control is the inner knob of the dual concentric rotary controls located on the front face of the cabinet. It is used to set the required audio output from the receiver. When turned fully clockwise the volume is at maximum, when rotated anti-clockwise the volume is reduced to a minimum.

The main shift control (MS) is the outer knob of the dual concentric rotary controls. It is only used for Single Side Band (SSB) reception, please see the section on SSB for a fuller explanation. It's normal position is 12 o'clock.

3. SQL (squelch) and FS (fine shift) control. The squelch control is the inner knob of the dual concentric rotary controls located on the front face of the cabinet. The control is used to eliminate unwanted background noise on unoccupied frequencies. It is also used by the receiver to decide when to stop during scan and search modes.

The squelch control requires careful setting to achieve optimum operating performance. Rotate the control clockwise until the background noise just disappears, this is the most sensitive setting of the control. In practice the control is usually rotated a little further clockwise to avoid stopping on noise or very weak and unreadable signals. If the control is rotated too far clockwise then weak signals will

be totally lost and only strong signals will be heard.

The fine shift control (FS) is the outer knob of the dual concentric rotary controls. It is only used for SSB operation and its action is similar to that of the MS control. The normal position for this control is 12 o'clock. Please see the SSB section for a fuller explanation.

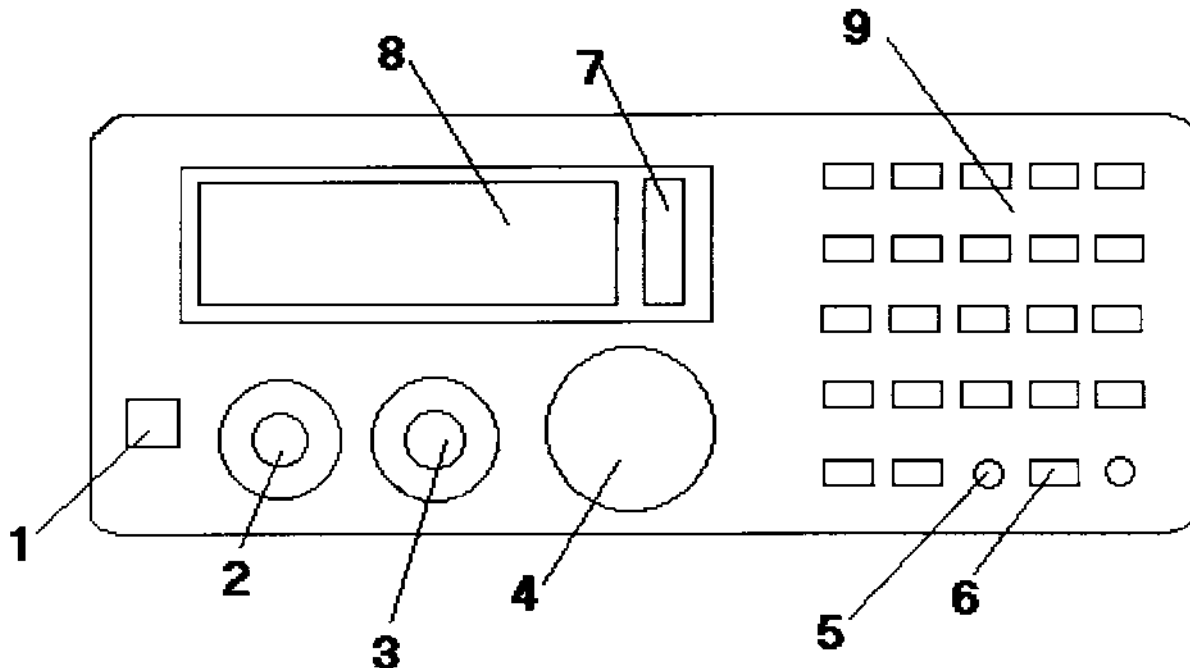

4. UP/DOWN (tuning) control. Located on the front face of the cabinet. Enables manual tuning of the receiver when correctly programmed. Due to the microprocessor resorting of frequencies, the operation of the control is 'jerky', this is normal. The UP - DOWN ARROW keys have a more positive action.

There is no manual tuning mode as such. If you wish to tune a through particular band you must use the programmed search facility for memories 63 to 78 and then force manual stepping. See the sections on MANUAL and SEARCH mode for further information.

5. KEY LOCK (indicator). This red LED illuminates to show when the keypad lock function has been activated.

6. BFO (Beat Frequency Oscillator) switch. This switch activates the internal BFO to enable reception of SSB transmissions while in the AM (Amplitude Modulation) mode. The switch has two positions, ON and OFF. The normal position for this switch is OFF. Please refer to the SSB section for a fuller explanation.

A red LED indicator to the right of the switch is illuminated when the function is activated.

7. S-meter (Signal meter). This vertical line of LEDs (Light Emitting Diodes) is located to the right of the display. When the receiver is tuned to a signal this indicator provides an indication of receive signal strength. This can be useful for comparison with other stations and to monitor fluctuating radio propagation from day to day.

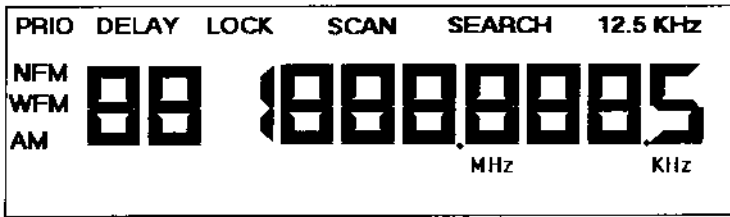

8. DISPLAY. Located on the front of the cabinet, it is a Liquid Crystal Display (LCD). Comprehensive information such as frequency, mode etcetera is displayed in an easy to understand format. The display is illuminated with a switchable small internal lamp to enhance visibility.

Due to the necessary design requirements of this multi-display, visibility may be poor from certain angles. Slightly lifting the front of the cabinet can improve visibility.

9. KEYBOARD. Located on the front of the cabinet to the right of the Liquid Crystal Display. The keyboard is laid out in a logical manner and is split into numeric and command areas.

0 to 9 The keys 0 to 9 plus the decimal point (.) are used for entering frequency, step size, memory channel number, bank number and so on.

(.) Press once to select a decimal point when entering frequency information. When pressed following the SHIFT key, the keypad is locked to prevent accidental frequency change.

SHIFT The shift key is very important and is used to select the second functions of the front panel (NFM, WFM, AM, 5k, 12.5k, 25k, LINK, UN-LINK, PRI, KEY-LOCK).

For example: To change the mode

PRESS SHIFT
the display will FLASH indicating all operations which may be selected.

PRESS NFM
You have now changed mode and the display will stop flashing to confirm operation.

The receiver will not resume normal operation until a function is selected or the SHIFT key is pressed a second time.

MAN/SCAN. This key places the receiver into several modes:

MANUAL - where frequencies can be keyed directly into the keypad.

SCAN - when on banks 1 to 62 rapidly checks (scans) frequencies previously stored into memory.

SEARCH - when on banks 63 to 78 causes the receiver to progressively move between programmed frequency limits (search).

When activated SCAN and SEARCH indicators appear on the Liquid Crystal Display (LCD) to indicate current operating mode. See sections on MANUAL, SCAN and SEARCH modes for more detail.

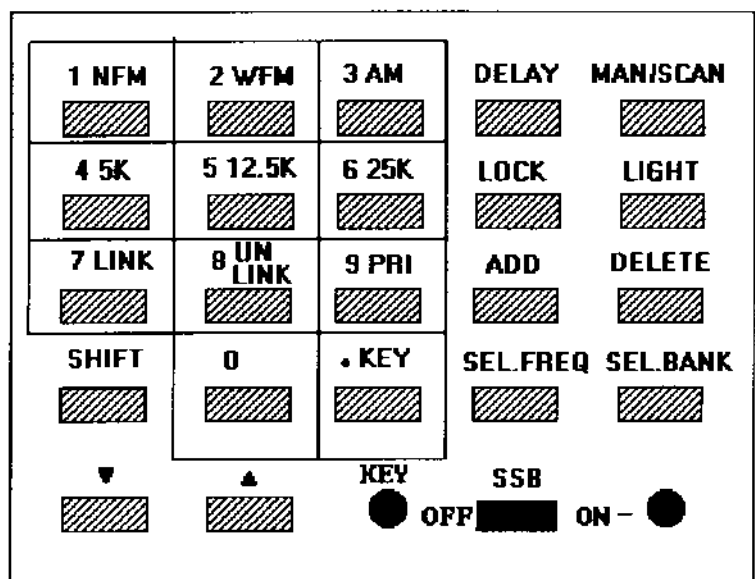

DELAY When activated the DELAY indicator appears on the LCD. In SCAN and SEARCH modes, the receiver will DELAY (pause) before moving to the next channel or increment when a busy channel becomes clear.

Pressing the DELAY key a second time cancels the operation.

LOCK This key is used while in SCAN mode to LOCK OUT a memory channel (when you no longer wish to listen to it). Pressing the key a second time unlocks the channel. The key is not used in MANUAL or SEARCH modes.

LIGHT For night time use this key activates a low intensity lamp behind the LCD. Pressing the key a second time switches the lamp off. When the set is switched on the light is always OFF.

ADD Pressing this key caused the displayed frequency to be added to the current memory bank. (Also used in SEARCH mode when programming the search edges). If the display shows "FULL" you must first delete other entries to make room for the new frequency or select another bank.

DELETE Pressing this key will DELETE the displayed frequency from the current SCAN or SEARCH bank.

SEL.FREQ This key has several actions depending on operating mode:

MANUAL - Used to enter a frequency after selection from the keypad. If pressed repeatedly, it allows you to view the contents of the current memory and then any other LINKED memory bank.

SCAN - When stopped on a busy channel, causes the receiver to move to the next lowest channel regardless of whether the channel is clear. The DOWN ARROW key has the same effect.

SEARCH - Causes the receiver to 'hop' to the lower/upper limit and start searching from the beginning. When programming the search limits, this key allows you to view the upper and lower limits.

SEL.BANK This key is used in MANUAL, SCAN and SEARCH modes to directly access a bank. Simply key in a number between 1 and 78 and press SEL.BANK.

When in MANUAL mode key the number of the desired bank and press SEL.BANK.

When in SCAN mode pressing the key repeatedly scrolls the receiver through ALL SCAN banks in ascending order. Holding down the key scrolls through banks at high speed.

When in SEARCH mode pressing the key repeatedly scrolls the receiver through ALL SEARCH banks in ascending order. Holding down the key scrolls through banks at high speed.

NFM Selected by pressing SHIFT then NFM (1), an NFM indicator is displayed on the LCD. This mode of operation is used by most services other than airband (including VHF-UHF Amateur Band), NFM stands for Narrow band Frequency Modulation.

WFM Selected by pressing SHIFT then WFM (2), a WFM indicator is displayed on the LCD. This mode of operation is used mainly by BAND-2 broadcast stations, WFM stands for Wide band Frequency Modulation.

AM Selected by pressing SHIFT then AM (3), an AM indicator is displayed on the LCD. This mode is used by most Airband and some other services. AM stands for Amplitude Modulation.

5k 12.5k 25k Selected by pressing SHIFT followed by 5k (4), 12.5k (5) or 25k (6). This sets the channel step when programming the SEARCH bank information.

LINK Selected by pressing SHIFT followed by LINK (7). This facility is used in SCAN mode for banks 1 to 62. Unless scan banks are LINKED, each bank of 32 channels will be scanned individually. Should you wish to scan more than 32 channels at any one time, you must LINK banks together. See the section on SCAN mode for more information.

UNLINK Selected by pressing SHIFT followed by UN-LINK (8). This facility is used in SCAN mode for banks 1 to 62. Unless scan banks are LINKED, each bank of 32 channels will be scanned individually. Should you wish to scan more than 32 channels at any one time, you must LINK banks together. UN-LINK reverses this situation in order to isolate the desired bank from others. See the section on SCAN mode for more information.

PRI PRIORITY MODE is activated by pressing SHIFT followed by PRI (9), the same sequence deactivates the facility. Priority operates in SCAN mode and causes **SCAN BANK 1** to be scanned following every other bank even if linked.

For example: If banks 6, 7 and 8 are linked with the priority activated the sequence would be

1, 6, 1, 7, 1, 8, 1 etc

It is important to keep only interesting frequencies in BANK 1 for this reason.

KEY-LOCK This facility is selected by pressing SHIFT followed by (.) the decimal point key and disables all other keypad functions. A KEY-LOCK LED indicates when activated. The facility can be de-selected by again pressing SHIFT followed by (.)

▼ **DOWN ARROW.** Used in MANUAL, SCAN and SEARCH modes to force the movement onto the next increment or channel. Operation is similar to the rotary control but has a more positive action.

▲ **UP ARROW.** Used in MANUAL, SCAN and SEARCH modes to force the movement onto the next increment or channel. Operation is similar to the rotary control but has a more positive action.

Rear panel:

A. ANT (aerial) connector. This is a standard BNC type. It's operation is like a bayonet (push and twist) and is mounted on the rear face of the case. The supplied aerial may be connected to this point or a mobile / base system.

In elevated locations or when close to transmitters, you may encounter overloading (refer to "D" the attenuator switch). When connecting long wire aerials for shortwave, you need only connect the wire to the centre pin of the BNC plug. Connecting the outer screen of the BNC plug to a GOOD EARTH point can improve reception and reduce noise.

B. DC12V (DC power input) socket. Located on the rear of the case, the socket is of the dual concentric type and is CENTRE POSITIVE. The provided power supply or DC lead should be connected to this point.

Any suitable regulated DC supply of 11 to 16 Volts and 1 Amp (or more) current capacity may be connected to this socket. Superior SSB audio quality is gained by using such a device.

C. EXT SPKR (external speaker) socket. Located on the rear face of the cabinet. This is a standard 3.5mm mono socket. Either an earphone or small external speaker may be connected,

when in use the internal speaker is automatically disconnected. The impedance of an external device should be 8 OHMS or greater.

D. ATT (attenuator) switch. The switch has two positions marked as LOCAL and DX. For most situations the DX position is used where the receiver is at its most sensitive.

When operating the receiver in the presence of strong signals such as those from TV, broadcast, taxi, police etcetera, some interference may be experienced. This interference can take many forms such as an increase in background noise, desensitising of the receiver or mixing of many stations together.

The cure for most of these effects is to use the attenuator switch in the LOCAL position. This reduces the level of signals reaching the receivers circuitry and helps the set cope with strong signals. When receiving on shortwave using long wire aerials, dipoles or similar this switch should be in the LOCAL position (especially when using SSB).

The addition of the attenuator switch to the receiver allows the set to be sensitive when required for weak signal listening and provide a reduction in overloading when necessary.

E. RS232C (Computer control) socket. This 9 pin 'D' type socket allows connection and control from a personal computer. Controlling software will be required. Please see the more detailed information towards the rear of this manual.

Operation

After unpacking the receiver, ensure the power switch is switched off then connect the power supply to the DC input on the rear of the case.

The receiver should be switched on by depressing the power switch.

With the squelch control turned fully anti-clockwise to allow sound from the speaker, the volume should be adjusted to a comfortable level. It is never a good idea to switch on the receiver with an earphone connected.

The squelch control should be rotated clockwise until the background noise is just cancelled. This is known as 'threshold' and is the most sensitive setting for the squelch control. If you find setting the squelch difficult, try removing the aerial from the receiver.

Occasionally when entering or moving frequency the word "PAUSE" is shown on the LCD. This is to inform you that the receivers circuitry (microprocessor, PLL and VCO) is acting on your instruction but may take a second to fully comply. This is usually the case when you have requested a large change in frequency etc.

Manual operation

1. To ENTER a FREQUENCY.

Key in the digits and use the decimal point after the MHz. You don't have to enter the following zeros' as they will be added automatically after pressing the decimal point and SEL.FREQ. In fact you can usually leave out the decimal point when entering a round MHz.

(Frequency in MHz) **SEL.FREQ**

Example: **131.000 - SEL.FREQ**

Or: **131 - SEL.FREQ**

2. To CHANGE MODE.

To change mode from that on the LCD

Press **SHIFT - MODE - (NFM, WFM, AM)**

Example: To select AM mode

Press **SHIFT - AM**

You will note that when **SHIFT** is pressed, the display **FLASHES** to confirm operation and to indicate which variables may be changed.

3. TUNING the receiver.

You cannot simply start 'tuning' through frequencies. First you must prepare the receiver by specifying various information. You must specify the **MODE**, **STEP SIZE**, **LOWER FREQUENCY LIMIT** and **UPPER FREQUENCY LIMIT**. This information is stored in one of the 16 **SEARCH** banks between 63 and 78.

When programming the upper and lower frequency limits, ensure both the mode and channel step are the same... if you follow the example they will be!

Example: To 'tune' across the 2m Amateur band between 144 and 146 MHz in 25 kHz steps and NFM using search bank 63.

Select bank

Delete lower frequency limit

Delete upper frequency limit (this frequency remains on the display at this point but don't worry!)

Select mode

Select step size

Input lower frequency limit

Input upper frequency limit

Confirm programming

Example: Press **63 - SEL.BANK - SEL.FREQ - DELETE - SEL.FREQ - DELETE - SHIFT - NFM - SHIFT - 25kHz - 144 - ADD - 146 - ADD - SEL.FREQ - SEL.FREQ**

The **UP-DOWN ARROW** keys may now be used to 'tune' through the band, their action is very positive. The rotary control may also be used but may appear 'jerky' in operation especially when tuning anti-clockwise (downward in frequency) - this is normal and is a product of the microprocessor reshuffling and sorting of frequencies.

You may key any start frequency directly into the receiver between the two programmed limits and then tune away. For instance, let's say you want to start at 145.600 MHz

Press: **145.6 - SEL.FREQ**

Then use the UP-DOWN ARROW keys or rotary control.

4. Flexibility.

You can programme up to 16 (SIXTEEN) different frequency bands to be manually tuned or searched automatically (between banks 63 and 78 inclusive).

If you no longer wish to manually TUNE, press **MAN/SCAN** to activate the automatic band SEARCH. A SEARCH indicator is shown on the LCD to confirm operation. Pressing **MAN/SCAN** a second time returns you to manual tuning.

5. Single Side Band (SSB) mode.

This advance mode is a special form of communications used for point-to-point contact mainly on shortwave, this includes long range oceanic traffic, marine and amateur band. Amateur band radio enthusiasts also use SSB to increase the distance covered (DX=Long Distance) on the VHF 144 MHz (2m) band and UHF 432 MHz (70cm) band.

SSB is divided into two main types, Upper Side Band (USB) and Lower Side Band (LSB). Morse code, which is sometimes referred to as continuous wave (CW) may also be received in the SSB mode. Received audio may sound a little strange at first (many people comment that it sounds like Micky Mouse or Donald Duck), this is normal. With a little practice you will soon get used to the tone, results can be very surprising so stick with it.

A Beat Frequency Oscillator (BFO) is used in the AM mode. The MS (Main Shift) and FS (Fine Shift) controls are used for fine tuning and clarifying the received signal. Although the receiver is compact and features no specific SSB filter the results can be very good.

1. Programme a SEARCH bank (between 63 and 78) as shown earlier in 'item 3 TUNING the receiver' and prepare for manual tuning. A good place to start is the 20m amateur band between 14.000 and 14.350 MHz, AM mode and 5kHz step size.

2. Select the pre-programmed bank

3. Ensure the MS and FS controls are in the 12 o'clock position.

4. When tuning on shortwave using an external aerial, switch the rear panel attenuator to LOCAL.

5. SWITCH ON THE BFO.

6. Key in the start point such as 14.2 MHz

Press **14.2 - SEL.FREQ**

N.B. Although you may not be able to enter exact frequencies (such as 10.051 MHz), the MS and FS controls will effectively allow you to tune in between the gaps to provide coverage throughout the receiver's range. When you key in a frequency, the receiver will select and display the closest 5 kHz increment as the starting point.

7. Open the squelch by rotating the SQUELCH control fully anti-clockwise so that background noise is heard.

8. Use the UP-DOWN ARROW keys to tune as close to the desired frequency as possible (you may

also use the rotary control but may find it's operating 'jerky'). The UP ARROW increases frequency as does clockwise rotation of the tuning control.

9. Rotate the MS control to further resolve the received signal. Clockwise rotation increases the received frequency. The range of the MS control is approximately - 4 kHz to + 6 kHz with zero being at the 12 o'clock position. (This means that ALL frequencies can be covered).

It does take a bit of getting used to:

USB - Clockwise rotation of the tuning, MS and FS controls increase frequency but lowers the pitch
 LSB - Clockwise rotation of the tuning, MS and FS controls increase frequency and increases the pitch

10. Adjust the FS control for further fine adjustment of pitch until the received signal is more natural in sound.

If the signal is particularly distorted and impossible to clarify, rotate the MS control 1 or 2 divisions in each direction and try again. Some practice will be necessary.

It is not possible to store SSB frequencies into memory. You may store them as AM but fine tuning will be required each time they are recalled.

Search Mode

Search mode is programmed in much the same way as MANUAL operation. It is intended to enhance the enjoyment of searching for new and unknown frequencies as well as evaluating the activity on known bands. Search takes the fatigue out of manual tuning and benefits by a much improved searching rate ensuring that little activity escapes your attention.

Search bank information is stored in an EEPROM (Electrically Erasable Programmable Read Only Memory) and will not be lost when the receiver is switched off. No back up battery is required.

You cannot simply start searching. First you must prepare the receiver by specifying various information. You must specify the MODE, STEP SIZE, LOWER FREQUENCY LIMIT and UPPER FREQUENCY LIMIT. This information is stored in one of the 16 SEARCH banks between 63 and 78.

1. Programming SEARCH banks.

When programming the upper and lower frequency limits, ensure both the mode and channel step are the same... if you follow the example they will be!

Example: To search across the 2m Amateur band between 144 and 146 MHz in 25 kHz steps and NFM using search bank 64.

Select bank
 Delete lower frequency limit
 Delete upper frequency limit (this frequency remains on the display at this point but don't worry!)
 Select mode
 Select step size
 Input lower frequency limit
 Input upper frequency limit
 Confirm programming

Press **64 - SEL.BANK - SEL.FREQ - DELETE - SEL.FREQ - DELETE - SHIFT - NFM - SHIFT - 25kHz - 144 - ADD - 146 - ADD - SEL.FREQ - SEL.FREQ - MAN/SCAN**

Press **MAN/SCAN** to activate (The LCD SEARCH indicator confirm operation)

Pressing the **SEL.FREQ** key while searching returns you to the upper frequency limit to start searching downward again.

Searching is from the upper to the lower frequency limit in descending order, you cannot reverse the search direction.

2. Manual over-ride.

If you no longer wish to automatically search (or want to remain on an interesting frequency), press **MAN/SCAN** to activate the MANUAL tuning mode. The SEARCH indicator on the LCD is extinguished to confirm operation. You may also commit the new frequency to memory. Pressing **MAN/SCAN** a second time returns you to automatic searching.

3. Selecting a new bank.

You can programme up to 16 (SIXTEEN) different frequency bands to be manually tuned or searched automatically (between banks 63 and 78 inclusive). Only one bank can be searched at any time.

To access another search bank simply type in the number followed by **SEL.BANK**. The bank indicator is shown to the left of the frequency readout.

Example: To select search bank 70

Press **70 - SEL.BANK**

When in search mode, pressing **SEL.BANK** repeatedly without a number advances to the next search bank, then the next and so on until you loop back to the starting point. Holding down **SEL.BANK** scrolls through the banks quickly.

4. Entering new frequencies from search into memory.

The memory channels are discussed in detail in the SCAN MODE section of this manual. Illustrated here is a simple method of entering new and interesting frequencies into memory for later review.

When searching let's assume the receiver stops on 131.950 MHz AM while in search bank 65 and we wish to store the frequency into memory bank 5. (You will have first made sure that there are spare channels in bank 5, refer to the scan section for more detail).

Press **5 - SEL.BANK - ADD - 65 - SEL.BANK - MAN/SCAN**

It's a little 'long-winded' but you soon get the hang of it. If the memory bank had been full, the message "FULL" would have been displayed on the LCD and the frequency would not have been added to the memory bank. For this reason ALWAYS keep a memory bank in a ready state for memory input.

5. Notes on searching.

It is recommended not to specify frequency limits too wide apart when 'automatic' search is required. Although very fast searching is accomplished, it can still take a relatively long time to cover many tens of MHz allowing transmissions to 'get away' un-detected. Concentrate on a few MHz at a time until the picture of activity is established.

N.B. If you haven't previously stored information into a bank, spurious characters or the number "15" can be displayed to the right of the bank number - this is normal. The 'S-meter' often indicates the presence of a signal in this situation and should be ignored.

6. Delay key.

The DELAY key causes the receiver to 'wait' for a short while before continuing with the search once a signal has disappeared. This can be useful for airband listening etc.

SCAN mode.

Manually changing frequency and searching large areas can be a relatively slow process. In order to 'catch' brief bursts of communications such as from control towers to aircraft requires a faster method of frequency change.

For this reason and to increase pleasure of operation 'memory banks' may be SCANNED under control of the receiver's microprocessor. The receiver is capable of scanning many memory channels per second.

It is usually convenient to 'group' all similar frequencies together to enable their selection independently from other programmed channels. For example you could store ALL VHF airband frequencies in BANK 2 instead of randomly throughout the entire 62 banks.

There are 62 separate memory banks, numbers 1 to 62. Each memory bank contains 32 locations for frequency store totalling 1984 memories in all! Memories store frequency and mode.

To increase scan speed, the receiver indexes all frequencies within a bank into descending numerical order. The receiver organises the contents in this manner to ensure the fastest possible scan speed with the best possible chance of signal locking.

Newly added frequencies are added to the memory bank by numerical order and not by channel number. The resulting lack of channel number is not a great problem when you consider just how quickly a memory bank can be scanned. The individual contents of a bank can easily be reviewed.

To achieve the highest possible scan speeds it is recommended to keep all memories in any one bank not more than 25 MHz apart from one another, ideally 2 to 3 MHz where possible. The same applies to linking two or more banks where widely spaced frequency jumps are required. If large jumps are necessary between banks, the microprocessor will calculate the difference and insert a delay to help ensure signal lock. However, you may want to enter a few intermediate 'buffer' frequencies in the lower numbered bank as a transition for the synthesiser to ensure the highest probability of locking onto weak signals.

32 channels (one bank) is not always enough to store all frequencies to be scanned. For this reason it is possible to LINK banks together so that more channels can be scanned. It is even possible to scan all 1984 memory channels at the same time if desired.

Individual memory channels may be 'locked out' of scan when not required and reinstated at a later date.

Memory bank 1 can be used as a **PRIORITY** to keep an eye on those important frequencies (of course it can be used as a normal memory bank as well).

The **DELAY** key causes the receiver to 'wait' for a short while before continuing with scan once a signal has disappeared. This can be useful for airband listening etc.

1. Preparing for memory input.

If you haven't previously stored information into a bank, spurious characters or the number "15" can be displayed to the right of the bank number often accompanied by the channel lock indicator - this is normal. The 'S-meter' often indicates the presence of a signal in this situation and should be ignored.

Unfortunately these entries can stop the receiver from scanning and should be deleted. It is recommended that at least one frequency be entered into each bank to make this process easy.

Select a memory bank between 1 and 62

Example: To select memory bank 2

Press **2 - SEL.BANK**

The memory bank number will be shown to the left of the frequency readout. Ideally the bank number should be flashing to show that it is not linked to any other memory banks. If it is not flashing:

Press **SHIFT - UNLINK**

The bank indicator will flash to show the bank is unlinked.

Key in a new frequency for reference:

Example: **131 - SEL.FREQ - ADD**

Repeatedly press **SEL.FREQ** to review the contents of the memory bank using 131.000 MHz as your reference so that you know when you get back to the start point. (Remember, the memory channels are not numbered).

2. Entering frequency and mode into memory - use of the **ADD** key.

Now that you have prepared each bank as shown in item 1, you are ready to input your frequencies.

Example: Let's assume that you wish to enter 145.600 MHz NFM into BANK 3:

Press: **SHIFT - NFM - 145.6 - SEL.FREQ - 3 - SEL.BANK - ADD**

(**MODE - FREQUENCY - BANK - ADD**)

You may see the word "PAUSE" appear on the display while the set thinks about it! If the word "FULL" is displayed, you must first delete other frequencies from the memory bank to make room for the new ones.

You may review the contents of the memory bank by pressing **SEL.FREQ** repeatedly. It is best to do this with the bank **UNLINKED** or **ALL LINKED MEMORY CONTENTS** will be reviewed and not just the bank in question.

To **UNLINK** the memory bank press:

SHIFT - UNLINK

Note: The new frequencies are **NOT** permanently stored until you change to another bank. This is to provide the longest life expectancy for the EEPROM device. Should you switch the receiver **OFF** before changing bank, your new entries will not be saved.

3. Deleting channels from memory banks.

For many reasons you may wish to delete the contents of a memory bank, either in preparation for it's use or in making room for new frequencies to be added.

Example: Let's assume that you want to clear memory bank 6 of all entries:

Press: **6 - SEL.BANK**

(This has selected the appropriate bank)

If you wish to delete the displayed frequency

Press: **DELETE**

The receiver deletes the frequency and moves onto the next in the bank, you will notice that the list of frequencies is in descending order. If you wish to retain a specific channel but continue with the procedure:

Press: **SEL.FREQ**

to move to the next channel.

It is best to do this with the bank **UNLINKED** or **ALL LINKED MEMORY CONTENTS** will be reviewed (and possibly deleted by accident) and not just the bank in question.

To **UNLINK** the memory bank press:

SHIFT - UNLINK

4. Memory LOCKOUT.

From time-to-time you may wish to 'lock out' or 'skip' a busy channel that you no longer wish to listen to without deleting it.

When in **SCAN** mode and the receiver stops on an unwanted channel:

Press: **LOCK**

The receiver will move to the next channel in the bank or onto any other **LINKED** banks.

5. Reinstating locked out memory channels.

To reinstate locked out memory channels you must first scroll through the memory bank. For example: Let's presume that you have locked out memory channels from memory bank 2 which you now wish to scan again:

Press: **2 - SEL.BANK**

To first select the correct memory bank. It is best if the bank is UNLINKED or ALL linked memory bank contents will be reviewed. If the bank indicator to the left is flashing the bank is UNLINKED, if it is STABLE then:

Press: **SHIFT - UNLINK**

to unlink the bank. The bank indicator will remain static to confirm operation.

Press: **SEL.FREQ**

to review each channel in turn. Keep pressing SEL.FREQ to view the channels, the frequencies will be displayed in descending numeric order. LOCKED out memory channels will have an LCD indicator "LOCK". To UNLOCK a channel:

Press: **LOCK**

The LCD indicator will extinguish to confirm operation. Pressing LOCK will toggle the channel between locked and unlocked. You may use this procedure to LOCKOUT channels as well as unlock them if you prefer it to 'live lockout' while scanning.

7. Memory bank LINK and UNLINK.

From time-to-time you may wish to scan more than the 32 channels of a single memory bank. For this reason it is possible to LINK as many memory banks together as you choose from 1 to 62.

If you were to link memory bank 3 and 4 then a total of 64 channels can be scanned, if you link all memory banks then a total of 1984 memories can be scanned!

First check the memory bank status to see if it's LINKED. Example: To check the 'LINKED' status of memory bank 2:

Press: **2 - SEL.BANK**

If you have channels programmed into bank 2 a frequency will appear on the display with the number 2 to the left hand side. This is the bank number. If the number 2 is 'FLASHING' the bank is 'UNLINKED', if the number 2 is 'STATIC' then the bank is 'LINKED' to any other linked bank.

To LINK the bank:

Press: **SHIFT - LINK** (a 'static' display means linked)

To UNLINK the bank:

Press: **SHIFT - UNLINK** (a 'flashing' display means unlinked)

Of course there is a drawback. The more channels there are to scan, the longer it will take.

8. PRIORITY channel operation.

It is useful to store your most important frequencies into one memory bank which can be checked (scanned) on a regular basis.

The receiver uses memory bank 1 as a special 'priority' facility and operated only when in SCAN mode. When engaged "PRIO" is displayed and memory bank 1 is scanned after each linked bank.

Imagine that you are in SCAN mode and have linked banks 6, 7 and 8. You have activated priority and the "PRIO" is displayed. The scan sequence would be:

1, 6, 1, 7, 1, 8, 1 etc

The PRIORITY operates as a toggle on and off:

Press: **SHIFT - PRI**

9. Entering new frequencies from search into memory.

Illustrated here is a simple method of entering new and interesting frequencies into memory for later review.

When searching let's assume the receiver stops on 131.950 MHz AM while in search bank 65 and we wish to store the frequency into memory bank 5. (You will have first made sure that there are spare channels in bank 5).

Press **5 - SEL.BANK - ADD - 65 - SEL.BANK - MAN/SCAN**

It's a little 'long-winded' but you soon get the hang of it. If the memory bank had been full, the message "FULL" would have been displayed on the LCD and the frequency would not have been added to the memory bank. For this reason ALWAYS keep a memory bank in a ready state for memory input.

Computer control.

To increase versatility, the receiver has been equipped with an RS232 serial port for connection to most personal computers. An additional piece of software will be required to establish communications between the receiver and the computer.

Communications.

The receiver and computer communicate via the asynchronous RS232C serial port. A MAX232CW integrated circuit is used to provide communications. Available data transfer rates are 300, 1200 and 9600 baud with 8 bits, no parity and 1 stop bit.

The receiver will automatically detect the correct baud rate. Initially the computer must repeatedly send a carriage return character. When understood, the receiver responds by sending a carriage return / line feed sequence. (CR.LF). The word '**rS 232**' appears on the receiver's display.

To prevent the receiver from experiencing data overflow, the CTS line is used by the receiver to inform the computer that it is prepared to receive data.

To send data, the computer must first send a signalling character such as a space (the signalling

character is basically a request-to-send and is discarded). After the first signalling character is sent by the computer, the receiver responds by action followed by switching on CTS. This indicates to the computer that data may be transferred via TXD.

The connections to an IBM PC (and other computers) is as follows:

Computer (PC)	Description	AR2500
2	TXD	3
3	RXD	2
4	RTS	8
5	CTS	7
7	GND	5

The signals are used as follows:

TXD (Transmit data) transfer data from computer to receiver. Signals on this line are generated by the computer and are transferred to the receiver. The computer shall hold TXD in marking "1" condition during intervals between characters or words and at all times when no data is being transmitted. The computer shall not transmit data unless an ON condition is present on the CTS line.

RXD (Receive data) transfer data from receiver to computer. Signals on this line are generated by the receiver and are transferred to the computer. RXD shall be held in the marking "1" position. As long as the computer is not transmitting, the receiver assumes that the computer is ready to accept data.

RTS (Ready to send) the receiver assumes that the computer is ready to accept data.

CTS (Clear to send) data enabling signal line from receiver to computer. Signals on this circuit are generated by the receiver to indicate whether or not the receiver is ready to accept data.

GND (Ground) system ground.

Memory specific.

The receiver contains an 8k x 8 serial EEPROM which provides the storage for the 78 frequency banks (62 memory and 16 search). These are split into 62 SCAN banks with 32 frequencies per bank, and 16 SEARCH banks with 2 frequencies per bank.

The frequencies in all banks are stored in descending order. The frequency information is stored in a pseudo BCD number occupying 4 bytes of data. The least-significant byte contains mode information and the most significant 3 bytes contain the frequency.

Organisation of the stored frequency in 4 bytes:

Bytes	4	3	2	1
	MSD	.	LSD	FLAG

The flags currently contain 3 types of frequency information: MODE (AM, NFM, WFM), STEP-SIZE (5k, 12.5k, 25k), LOCKOUT

The flag that occupies the first byte is organised as follows:

Bits	7	6	5	4	3	2	1	0
AM	0	1	X	X	X	X	X	X
NFM	1	0	X	X	X	X	X	X
WFM	0	0	X	X	X	X	X	X
5k	X	X	0	1	X	X	X	X
12.5k	X	X	1	0	X	X	X	X
25k	X	X	1	1	X	X	X	X
LOCKOUT	X	X	X	X	1	X	X	X
EMPTY SLOT	0	0	0	0	0	0	0	0

There can be up to 8 digits on the LCD display to represent the current frequency. The LCD display format is:

MMMM.KKK.H

where MMMM = 5 to 1300 MHz

KKK = multiples of the step rate in kHz

H = multiples of the step rate in 0.5 kHz

Since the frequency is stored into nibbles, two digits must be dropped. The lowest digit (0.5 kHz multiple) can be dropped, since the software automatically detects when the unit is in the 12.5 kHz mode or when the frequency is a valid multiple of 12.5 kHz. The highest valid frequency is 15000 kHz, so the 7th and 8th digit (or the two most significant digits) can be represented as a BCD number.

Example: Here is the current frequency displayed on the computer.

LCD. 1250.987.5 12.5k/AM

Here is the same frequency represented as bytes in memory.

```
MSB ----- LSB
Freq 125 09 87 12.5k/AM
Memory C5 09 87 60
```

The frequency is always sent least significant byte first.

Command list:

The following sections outline valid commands to the receiver. Most of these commands directly emulate the keys on the front of the receiver. There are receiver upload and download commands that allow blocks of information to be communicated to and from the PC and receiver. There is also an automatic frequency output mode that will send the frequency and signal strength to the PC whenever squelch is released.

All commands are summarised in the following table.

AD	ADD CURRENT FREQUENCY TO BANK
AF	AUTO FREQUENCY MODE
AM	AM MODE (AM)
DE	DELETE CURRENT FREQUENCY
DL	DOWNLOAD
DN	DOWN ARROW
DY	DELAY
EB	ERASE BANK
FR	TUNE TO FREQUENCY
KL	KEYLOCK
LI	LCD LIGHT COMMAND
LK	LOCK
LN	LINK BANK
MA	MANUAL MODE
ME	SIGNAL STRENGTH METER
NB	NEW BANK
NF	NEXT FREQUENCY
NM	NFM MODE (NFM)
PR	PRIORITY
RF	RETURN CURRENT FREQUENCY
SC	SCAN MODE
SR	STEP RATE
UL	UPLOAD
UN	UNLINK BAND
UP	UP ARROW
VR	VERSION NUMBER
WM	WFM MODE (WFM)

NOTES:

- ◆ Unless otherwise stated, all characters transmitted are ASCII.
- ◆ Command strings contain no spaces unless otherwise noted.
- ◆ The string CR/LF terminates all communication from the PC and the AR2500. The ASCII code for CR/LF is 0Dh 0Ah (hex) or 13 10 (decimal). The CR/LF sequence may be sent from the keyboard by typing **CONTROL-M CONTROL-J**. *Example:* To turn on the LCD light: **LLI1^M^J** The first 'L' is ignored, use no spaces.
- ◆ The communication routine will time-out after approximately 4 seconds of inactivity. (Exception: when the unit is detecting the baud rate)
- ◆ **Errors messages:**
 - ◆ ?? - generally means unknown command (or out-of sync)
 - ◆ ??T - Timing error (start flag, stop bit, command timeout)
 - ◆ ??F - Format error (wrong number of bytes in command)

Receiver direct control commands.

AD - ADD Current frequency to bank

Description: Adds a frequency to the bank. If the bank is not full, the frequency displayed on the

LCD is added to the current bank, and AR2500 returns a "Y" as confirmation. If the bank was full, and "N" is returned.

Command: AD, CR,LF

Returned: BYTE (Y.N), CR, LF

AF - AUTO FREQUENCY MODE

Description: This command puts the AR2500 into a mode where the frequencies are output automatically. The auto frequency mode is turned off by issuing a "0" with the AF command, and turned on with a "1".

Whenever squelch is released, the frequency is automatically output to the PC in the BCD format outlined above. As soon as squelch is detected, the signal strength is output (see ME command) followed by an asterisk (*).

Command: AF, BYTE, CR, LF

Returned: CR, LF

AM - AM MODE (AM)

Description: This command is used to set AM mode on on the receiver.

Command: AM, CR, LF

Returned: CR,LF

DE - DELETE CURRENT FREQUENCY

Description: This command is used to set AM mode on the receiver

Command: AM, CR, LF

Returned: CR, LF

DL - DOWNLOAD COMMAND

Description: Download a complete frequency bank from the PC to the AR2500. The DL command is issued, followed by 2 bytes (ASCII) specifying the bank, followed by the frequencies (pseudo - BCD format as outlined in Memory Specific section).

There are a maximum of 32 frequencies per bank (4 bytes/freq). Empty frequency slots are represented by zeros (4 bytes). Since banks are sorted in descending order, empty slots are always located at the end of the bank. Therefore, to minimise download time, at the first empty slot (4 zeros) a download can be terminated.

Command: DL, 2 bytes, 4 bytes/freq. (Non-ASCII), CR, LF

Returned: CR, LF

DN - DOWN ARROW COMMAND

Description: Duplicates the Down arrow function.

Command: DY, BYTE, CR, LF

Returned: CR,LF

DB - ERASE BANK COMMAND

Description: This command is used to erase the specified EEPROM memory bank, by issuing the EB command with a 2 byte (decimal) number representing the bank. The entire EEPROM can be erased by issuing the EB command with AL (all)

Command: EB, 2 BYTE, CR, LF
Returned: CR, LF

FR - TUNE TO FREQUENCY

Description: Tunes to specified frequency. The FR command must be issued with a 4 byte pseudo-BCD number that represents the desired frequency (as outlined in the Memory Specific section). Leading zeros must be issued for frequencies less than 100 MHz. The frequency command is issued in the following format:

Freq - 1250.987.5 12.5K/AM format - 60 87 09 C5
The flags are output first, followed by the least -significant digits of the frequency.

Command: FR, 4 BYTES (NON-ASCII), CR, LF
Returned: CR, LF

KL - KEYLOCK COMMAND

Description: Duplicates the Keylock function from the Keypad. The Keylock mode is turned off by issuing a "0" following the command bytes, or turned on with a "1".

Command: KL, BYTE, CR, LF
Returned: CR, LF

LI - LCD LIGHT COMMAND

Description: Controls the LCD backlight. The light is turned off by issuing a "0" with the LI command, and turned on with a "1".

Command: LI, BYTE, CR, LF
Returned: CR, LF

LK - LOCK COMMAND

Description: Lock out current frequency.

Command: LK, CR, LF
Returned: CR, LF

LN - LINK BANK COMMAND

Description: Link the current bank

Command: LN, CR, LF
Returned: CR, LF

MA - MANUAL MODE COMMAND

Description: This command puts the AR2500 into the manual mode. On receipt of the SP command, the unit stops scanning/searching, and remains tuned to the frequency currently displayed on LCD display.

Command: MA, CR, LF
Returned: CR, LF

ME - SIGNAL STRENGTH METER

Description: Return the signal strength of the current frequency. There are 10 LEDs on the unit that represent the current signal strength. The ME command returns a value from 0 to 10 (least-significant nibble in hex), that directly represent the number of LEDs that are set on. (The highest nibble is a 3, to allow the value to be printed as a number)

Command: ME, CR, LF
Returned: 1 BYTE (HEX), CR, LF

NB - NEW BANK COMMAND

Description: Command to change to specified bank. There are 78 valid banks (scan 1 - 62, search 63 - 78). To change to bank 50, issue the command MB50. If the NB command is issued with a zero (NB00), the bank is incremented to the next valid bank. Note that the scan and search banks wrap-around. For example, if increment past bank 62, the unit will wrap to bank 1.

Command: NB, 2 BYTES, CR, LF
Returned: CR, LF

NF - NEXT FREQUENCY COMMAND

Description: Increment to the next frequency in the current bank. The frequencies in each bank are organised in descending order. Issuing the NF command will increment to the next frequency, and if at the end of the bank will wrap-around to the first frequency.

Command: NF, CR, LF
Returned: CR, LF

NM - NARROW FM MODE (NFM)

This command is used to set NFM mode on the receiver.

Command: NM, CR, LF
Returned: CR, LF

PR - PRIORITY MODE COMMAND

Description: This command is used to put the AR2500 into priority mode. The priority mode is turned off by issuing a "0" following the command bytes, or turned on with a "1".

Command: PR, BYTE, CR, LF
Returned: CR, LF

RF - RETURN CURRENT FREQUENCY

Description: Returns the current frequency displayed on the LCD. The frequency will be returned as a 4 character pseudo-BCD number that represents the desired frequency (as outlined in the memory specific section). Leading zeros will be issued for frequencies less than 100 MHz. The frequency is returned in the following format:

Freq - 1250.987.5 12.5K/AM Format - 60 87 09 C5

The flags are output first, followed by the least significant digits of the frequency.

Command: RF, CR, LF
Returned: 4 BYTES (NON-ASCII), CR, LF

SC - SCAN MODE COMMAND

Description: This command puts the AR2500 into the SCAN or SEARCH mode depending on the bank number selected.

Command: SC, CR, LF
Returned: CR, LF

SR - STEP RATE

Description: Changes the current step rate. This command can be used to change the step-rate to

5K, 12.5, or 25K mode by issuing the SR command. With a 05, 12 or 25 respectively.

Command: SR, 2 BYTES, CR, LF

Returned: CR, LF

UL - UPLOAD COMMAND

Description: Upload a complete frequency bank from the AR2500 to the PC. The UL command is issued, followed by 2 bytes (ASCII) specifying the bank. On receipt of the command, the frequencies of the specified bank are uploaded. (in the pseudo-BCD format as outlined in memory specification section)

There are a maximum of 32 frequencies per bank (4 bytes/freq). Empty frequency slot is represented by zeros (4 bytes). Since banks are sorted in descending order, empty slots are always located at the end of the bank. Therefore, to minimise upload time, at the first empty slot (4 zeros) upload will be terminated by CR/LF.

Command: UL, 2 BYTE, CR, LF

Returned: 4 BYTES/FREQ (NON-ASCII), CR, LF

UN - LINK BANK COMMAND

Description: Unlink the current bank

Command: UN, CR, LF Returned: CR, LF

UP - UP ARROW COMMAND

Description: Duplicates the UP Arrow function

Command: UP, CR, LF Returned: CR, LF

VR - VERSION NUMBER

Description: Display the current version number

Command: VR, CR, LF Returned: CR, LF

WM - Wide FM Mode (WFM)

Description: This command is used to set WFM mode on the receiver.

Command: WF, CR, LF Returned: CR, LF

Specification:

Frequency ranges	5 MHz to 550 MHz and 800 MHz to 1300 MHz
Frequency steps	5 kHz, 12.5 kHz and 25 kHz
Sensitivity	NFM Approx 0.45 uV @ 12 dB SINAD, WFM Approx 1.0uV @ 12dB SINAD, AM Approx 1.0uV @ 10 dB S/N (across most of the range)
Receiving modes	AM, FM (narrow), FM (wide) and USB, LSB, CW with the BFO
Memory channels	1984 arranged as 62 banks x 32 channels
Scan / Search speed	Upto 36 channels per second approx depending on programming
Scan / Search delay time	Approx 2 seconds
Search banks	16 programmable by the user
Priority channels	Memory bank 1 is used for priority in SCAN mode
Audio output	500 mW into 8 OHMS @ 10% THD
Power supply	11 - 16V DC from external power supply (provided)
Aerial input	50 OHM BNC
Size	150 x 55 x 180mm approx
Weight	Approx 650g

*Instruction Manual
Version 2.02*

Specifications are subject to change without notice due to continuous development of the receiver. E&OE.